

GCA Weatherproof Covers

Reference: GCA4

Weatherproofing - to protect DIN 4.3-10 Connectors.

GCA 4 weatherproof and dust proof cover for 4.3-10 connectors are used to protect downward facing 4.3-10 DIN connectors at the base of antenna system devices such as Antenna, Diplexers and MHA's.



Material: UV resistant EPDM with temperature range: -50degC to +120degC

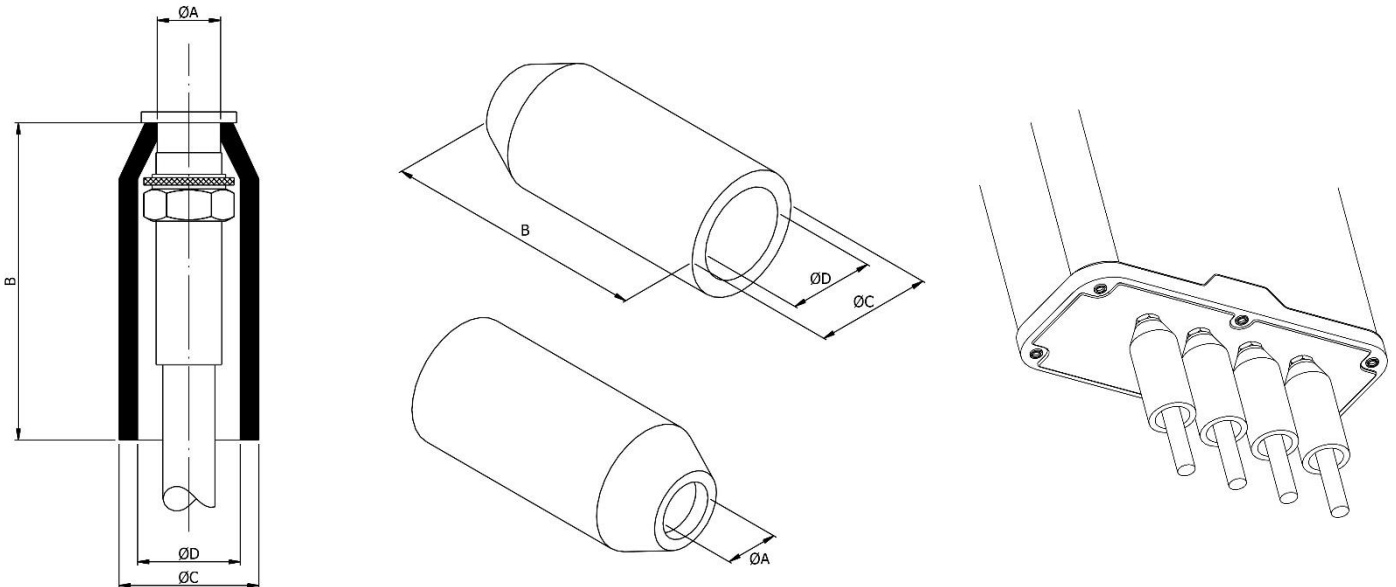

Cover Ref	Connector Size	Length (mm)	B	C	D	A	Material Thickness (mm)	Material
GCA 4	4.3-10 DIN	85	85	39	29	18	5	EPDM

GCA4 Weatherproof & Dust Covers – Installation Guidelines

Reference: GCA4

1. Install on Jumper before Connection

Pull the wider bottom end of the GCA 4 down over the male 4.3-10 nut before connection and tightening of the connector.

2. Push-Pull to install the GCA4

The GCA4 uses a tight tolerance so needs a simple 'push-pull' plunger motion to enable it to ride over the connector nut, recover its shape, and locate on the female connector under the antenna or MHA.

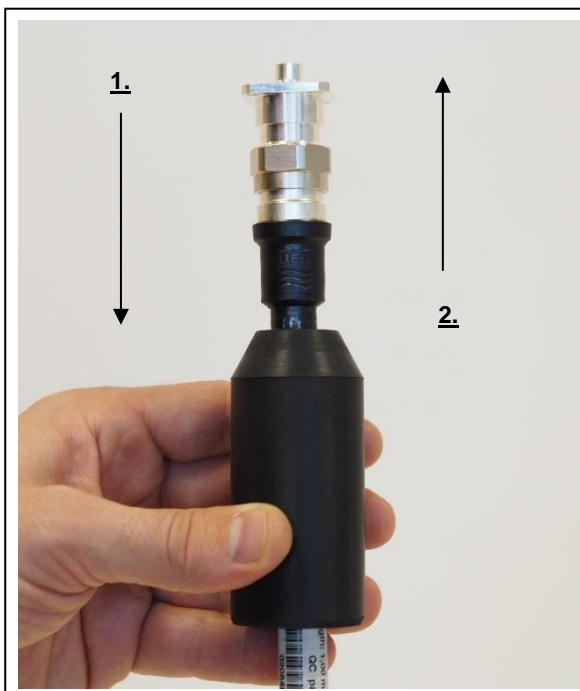

3. Finished location

Ensure the GCA4 has recovered its original shape and is pushed up flush against the connector mounting plate.

