

L5HF-S

4.3-10 Female for 7/8 in LDF5-50A cable

Product Classification

Product Type	Wireless and radiating connector
Product Series	LDF4-50A LDF5-50A
Ordering Note	CommScope® non-standard product

General Specifications

Body Style	Straight
Cable Family	AVA5-50
Inner Contact Attachment Method	Captivated
Inner Contact Plating	Silver
Interface	4.3-10 Female
Mounting Angle	Straight
Outer Contact Plating	Trimetal
Pressurizable	No

Dimensions

Length	64.01 mm 2.52 in
Diameter	34.8 mm 1.37 in
Nominal Size	7/8 in

Outline Drawing

L5HF-S

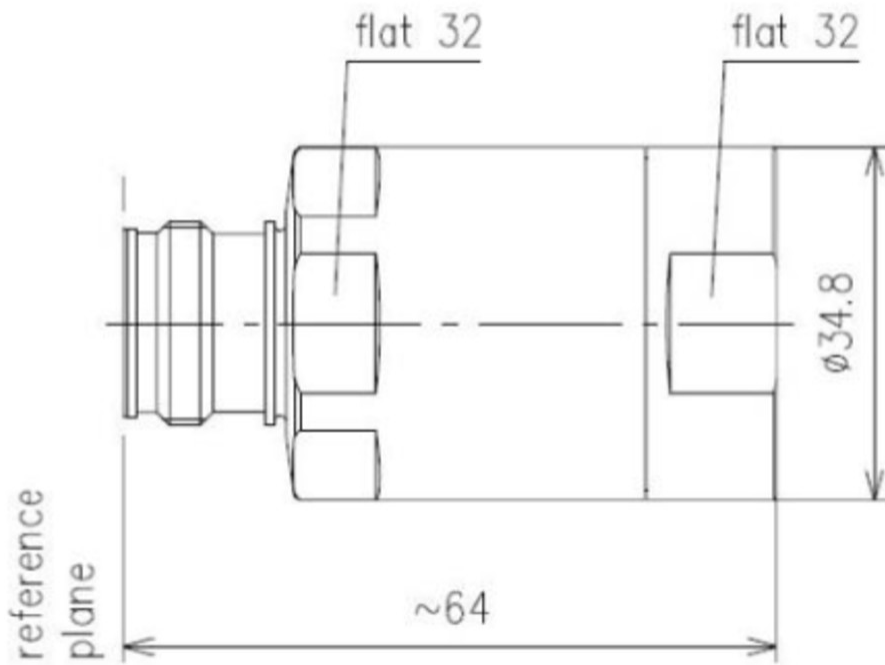

Electrical Specifications

3rd Order IMD at Frequency	-116 -dBc @ 1800 MHz
3rd Order IMD Test Method	Two +43 dBm carriers
Insertion Loss Coefficient, typical	0.05
Average Power at Frequency	3.0 kW @ 900 MHz
Cable Impedance	50 ohm
Connector Impedance	50 ohm
dc Test Voltage	4000 V
Inner Contact Resistance, maximum	0.4 mOhm
Insulation Resistance, minimum	5000 MOhm
Operating Frequency Band	0 – 3700 MHz
Outer Contact Resistance, maximum	1.5 mOhm
Peak Power, maximum	40 kW
RF Operating Voltage, maximum (vrms)	1415 V
Shielding Effectiveness	-130 dB

VSWR/Return Loss

L5HF-S

Frequency Band	VSWR	Return Loss (dB)
0–1000 MHz	1.02	40.09
1000–2700 MHz	1.041	33.94
2700–3800 MHz	1.065	30.04

Mechanical Specifications

Attachment Durability	25 cycles
Connector Retention Tensile Force	1,334.47 N 300 lbf
Connector Retention Torque	8.14 N-m 72.001 in lb
Insertion Force	200.17 N 45 lbf
Insertion Force Method	IEC 61169-1:15.2.4
Interface Durability	50 cycles
Interface Durability Method	IEC 61169-4:9.5
Mechanical Shock Test Method	IEC 60068-2-27

Environmental Specifications

Operating Temperature	-40 °C to +85 °C (-40 °F to +185 °F)
Storage Temperature	-55 °C to +85 °C (-67 °F to +185 °F)
Attenuation, Ambient Temperature	20 °C 68 °F
Average Power, Ambient Temperature	40 °C 104 °F
Corrosion Test Method	IEC 60068-2-11
Immersion Depth	1 m
Immersion Test Mating	Mated
Immersion Test Method	IEC 60529:2001, IP68
Moisture Resistance Test Method	MIL-STD-202F, Method 106F
Thermal Shock Test Method	MIL-STD-202, Method 107, Test Condition A-1, -55 °C to +85 °C
Vibration Test Method	IEC 60068-2-6
Water Jetting Test Mating	Mated
Water Jetting Test Method	IEC 60529:2001, IP66

Packaging and Weights

Weight, net	204 g 0.45 lb
--------------------	-----------------

Regulatory Compliance/Certifications

L5HF-S

Agency

CHINA-ROHS

ISO 9001:2015

ROHS



Classification

Above maximum concentration value

Designed, manufactured and/or distributed under this quality management system

Compliant/Exempted

* Footnotes

Insertion Loss Coefficient, typical 0.05√freq (GHz) (not applicable for elliptical waveguide)

Immersion Depth Immersion at specified depth for 24 hours